

- Page 1 - Block Diagram
- Page 2 - EP1S25 Bank 1/2
- Page 3 - EP1S25 Bank 3/4
- Page 4 - EP1S25 Bank 5/6
- Page 5 - EP1S25 Bank 7/8
- Page 6 - EP1S25 Control Signals
- Page 7 - EP1S25 Power
- Page 8 - Configuration ROM and JTAG
- Page 9 - Flash, RAM, LCD
- Page 10 - Status LEDs
- Page 11 - Power Supply 5v & 3.3USB
- Page 12 - Power Supply 3.3v, 1.5v, Sense
- Page 13 - HPI USB Interface
- Page 14 - Option Switches
- Page 15 - External Headers

Domain Technologies, Inc 972-578-1121 http://www.domaintec.com 811 E Plano Pkwy, #115, Plano TX 75074		
Title		
Stratix		
Size	Document Number	Rev
A	-	A
Date: 10/22/2004, 10:41 AM		Sheet 1 of 15

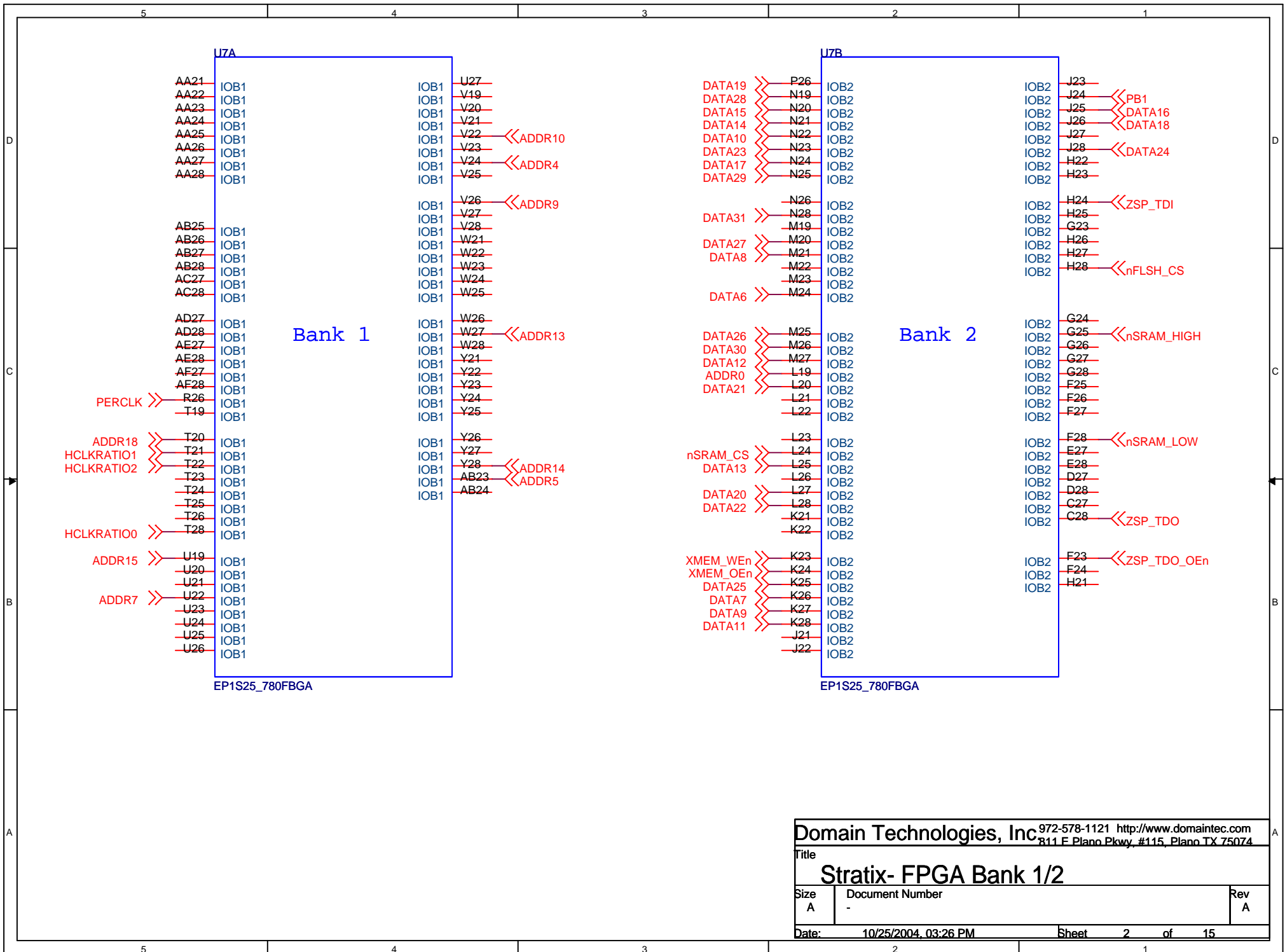

Title		
Stratix- FPGA Bank 1/2		
Size	Document Number	Rev
A	-	A
Date:	10/25/2004 03:26 PM	Sheet 2 of 15

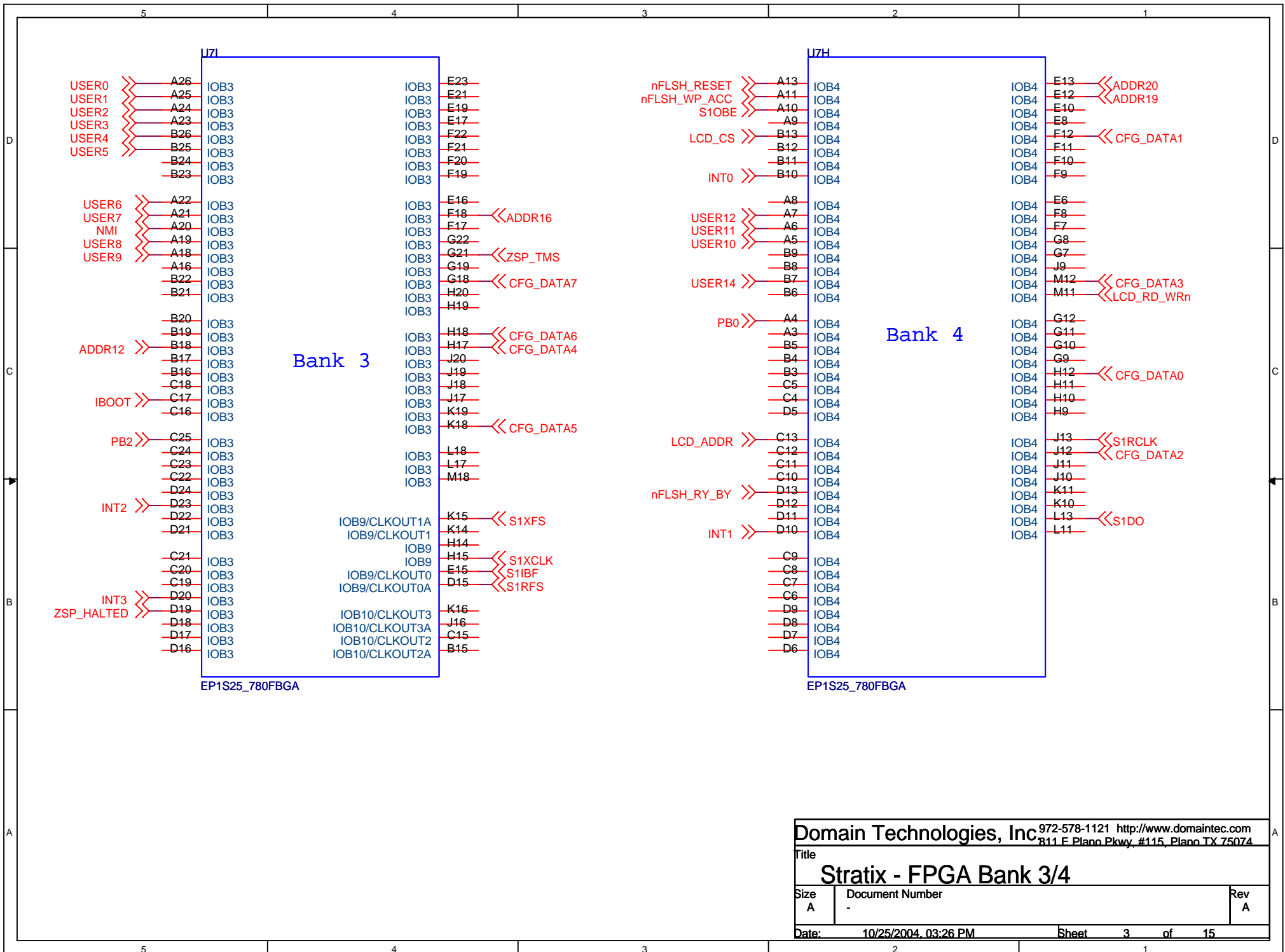

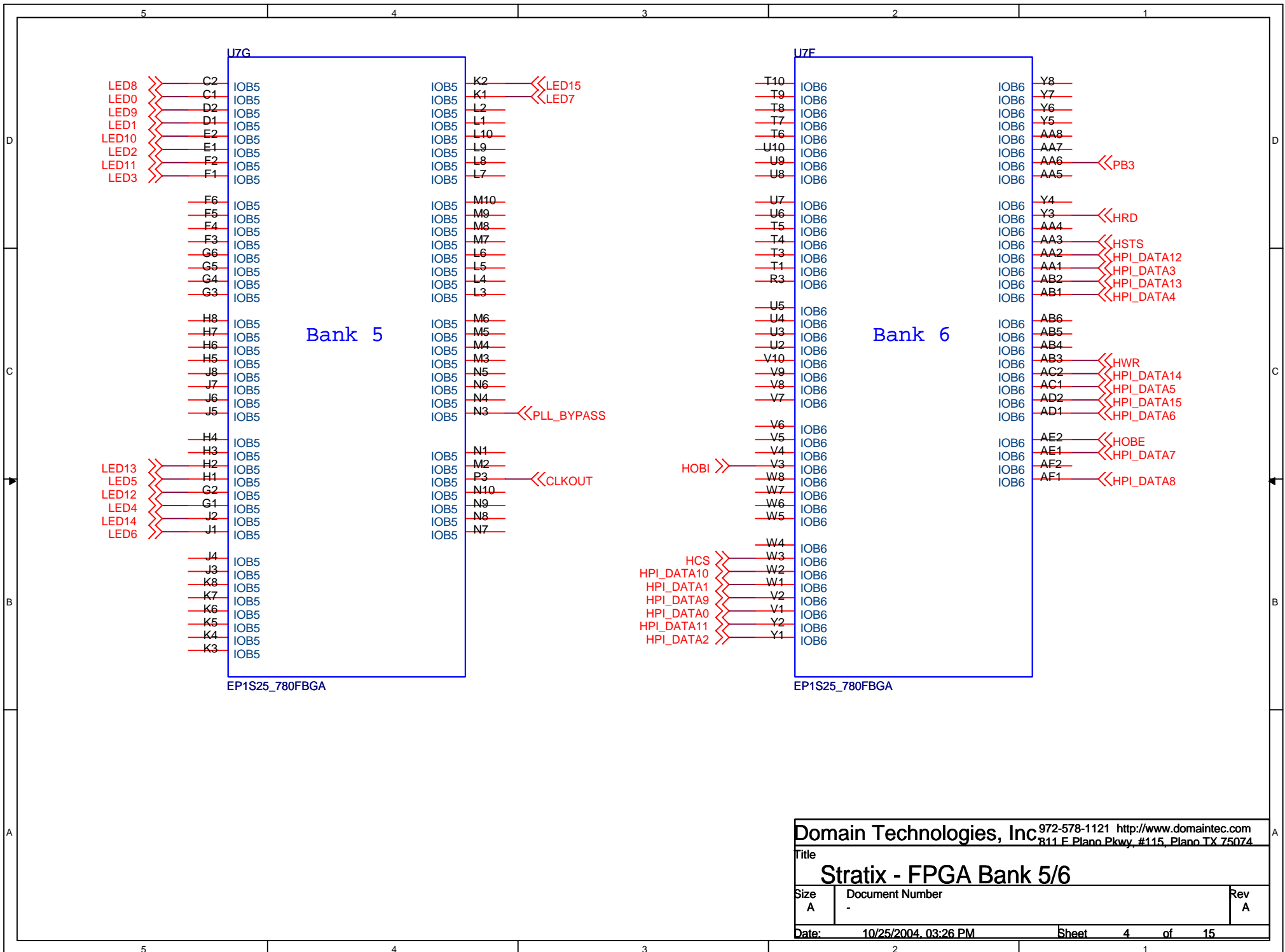

Domain Technologies, Inc 972-578-1121 <http://www.domaintec.com>
 311 E Plano Pkwy, #115, Plano TX 75074

Title		
Stratix - FPGA Bank 5/6		
Size	Document Number	Rev
A	-	A
Date:	10/25/2004 03:26 PM	Sheet 4 of 15

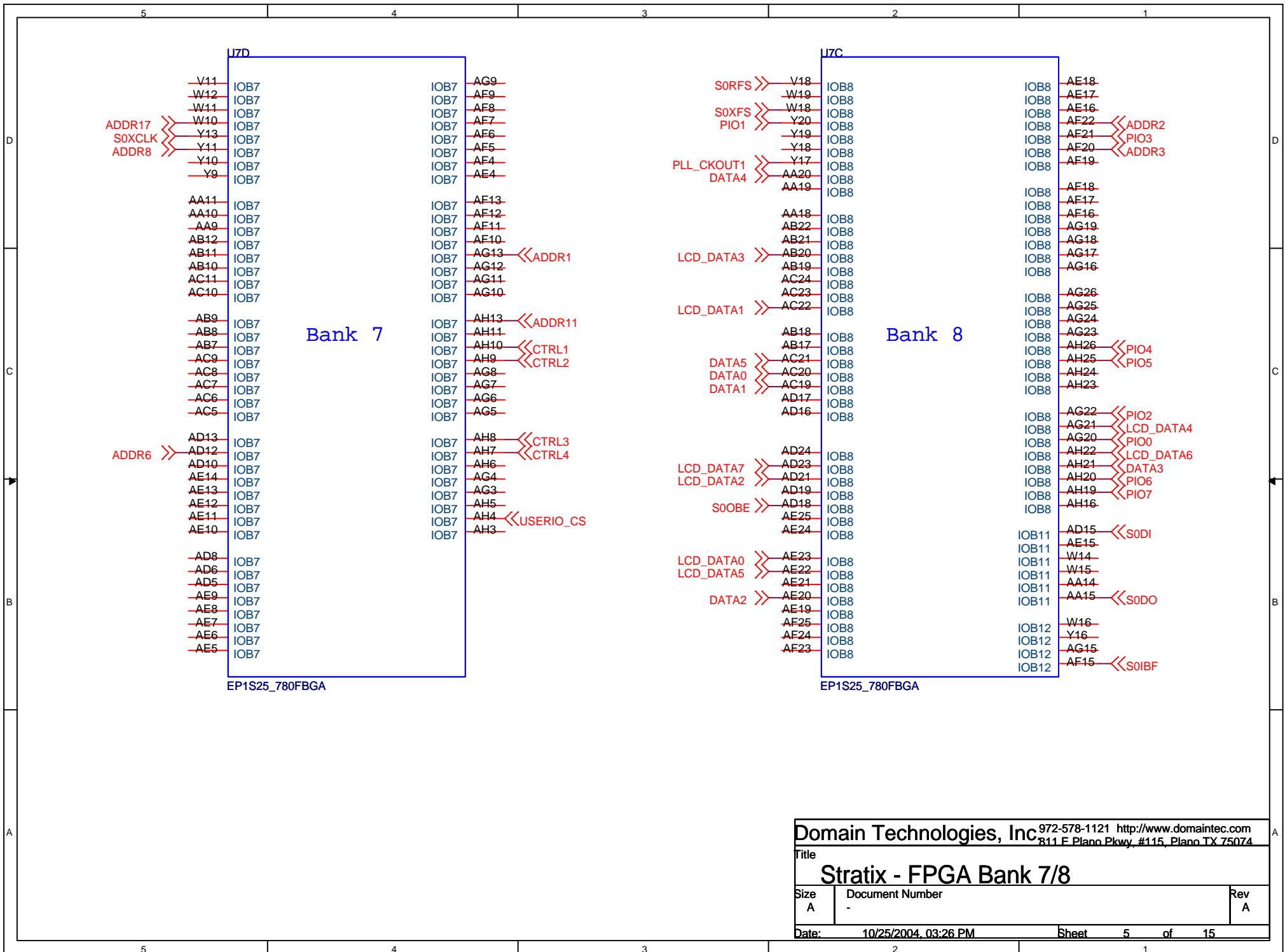

Domain Technologies, Inc 972-578-1121 http://www.domaintec.com 311 E Plano Pkwy, #115, Plano TX 75074		
Title		
Stratix - FPGA Bank 7/8		
Size A	Document Number -	Rev A
Date: 10/25/2004 03:26 PM		Sheet 5 of 15

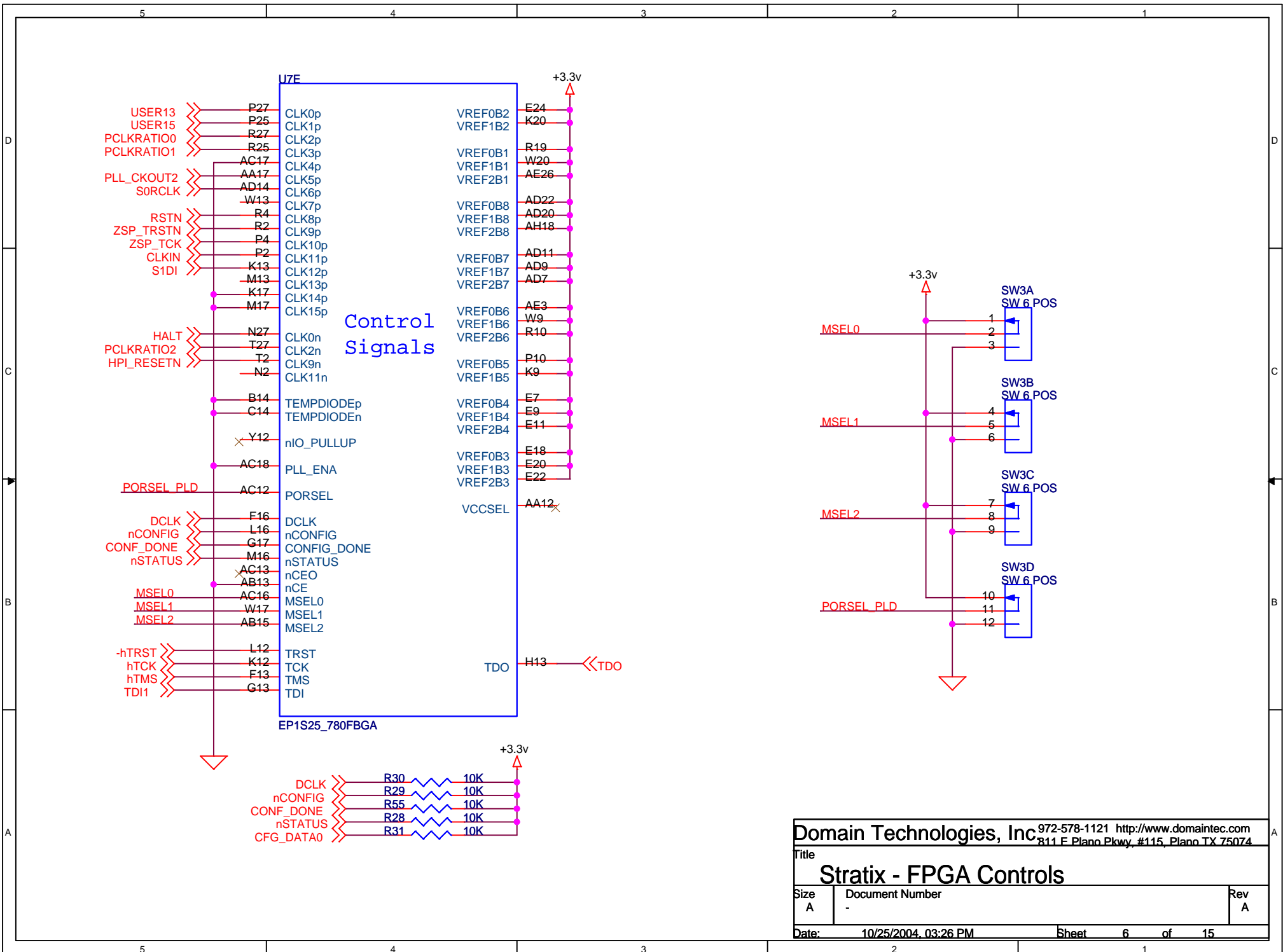

Domain Technologies, Inc. 972-578-1121 <http://www.domaintec.com>
 811 E Plano Pkwy, #115, Plano TX 75074

Title		
Stratix - FPGA Controls		
Size	Document Number	Rev
A	-	A
Date:	10/25/2004 03:26 PM	Sheet 6 of 15

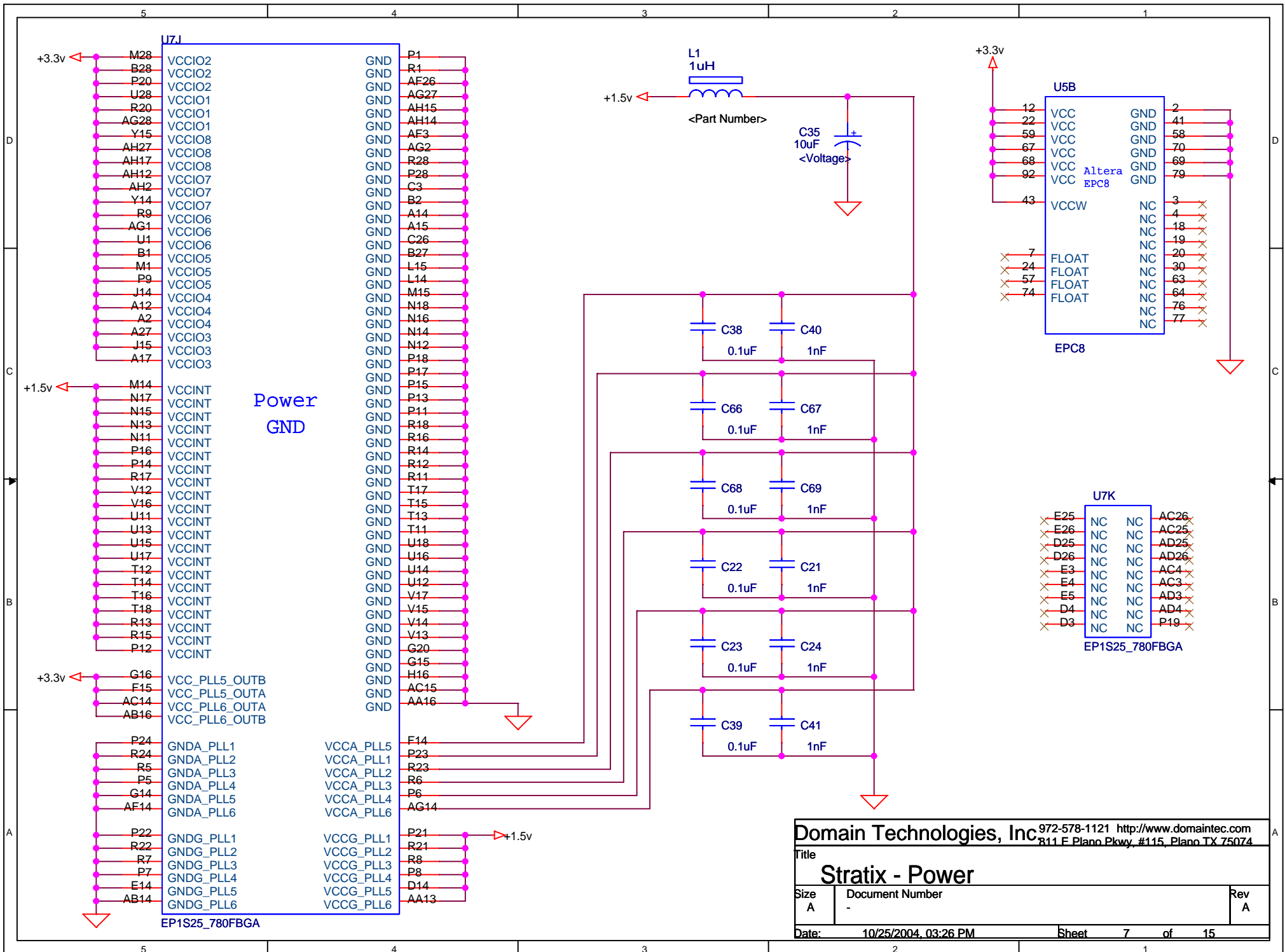

Domain Technologies, Inc 972-578-1121 <http://www.domaintec.com>
 811 E Plano Pkwy, #115, Plano TX 75074

Title		
Stratix - Power		
Size	Document Number	Rev
A	-	A
Date:	10/25/2004, 03:26 PM	Sheet 7 of 15

LSI JTAG PINOUT

-TRST	1	2	GND
TDI	3	4	GND
TDO	5	6	GND
TMS	7	8	GND
TCK	9	10	GND
EVT	11	12	key
-RST	13	14	VDD_SENSE

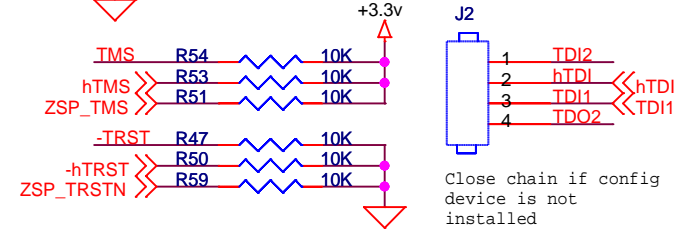
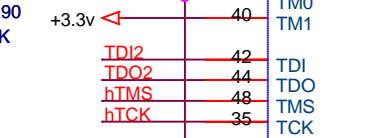
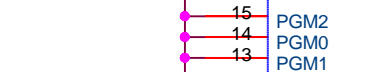
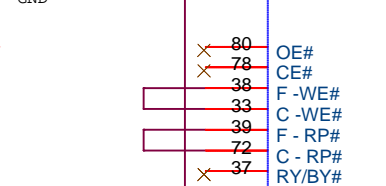
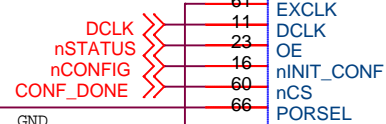
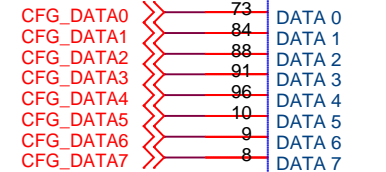
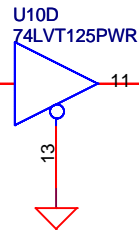
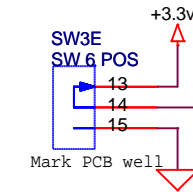
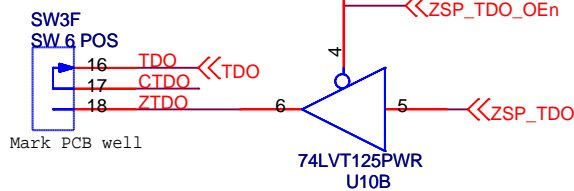
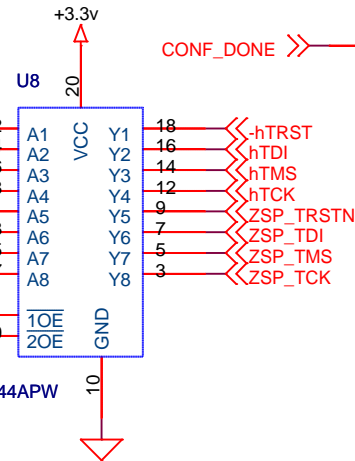
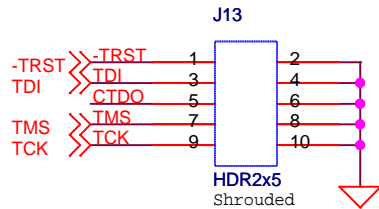
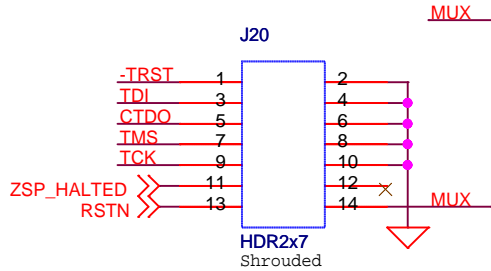
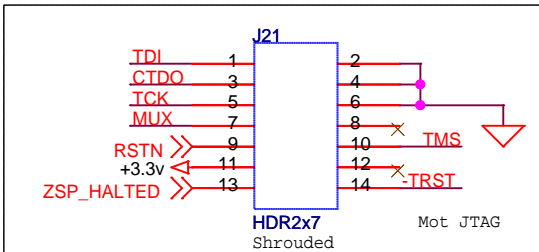
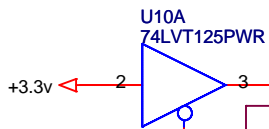
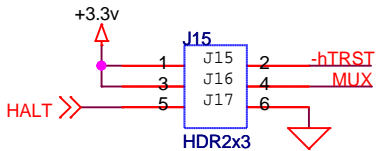
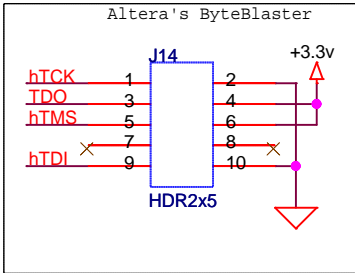

Close chain if config device is not installed

Domain Technologies, Inc. 972-578-1121 http://www.domaintec.com
811 E Plano Pkwy. #115, Plano TX 75074

Title		
Stratix - Config ROM. JTAG		
Size	Document Number	Rev
A	-	A
Date:	10/25/2004, 03:26 PM	Sheet 8 of 15

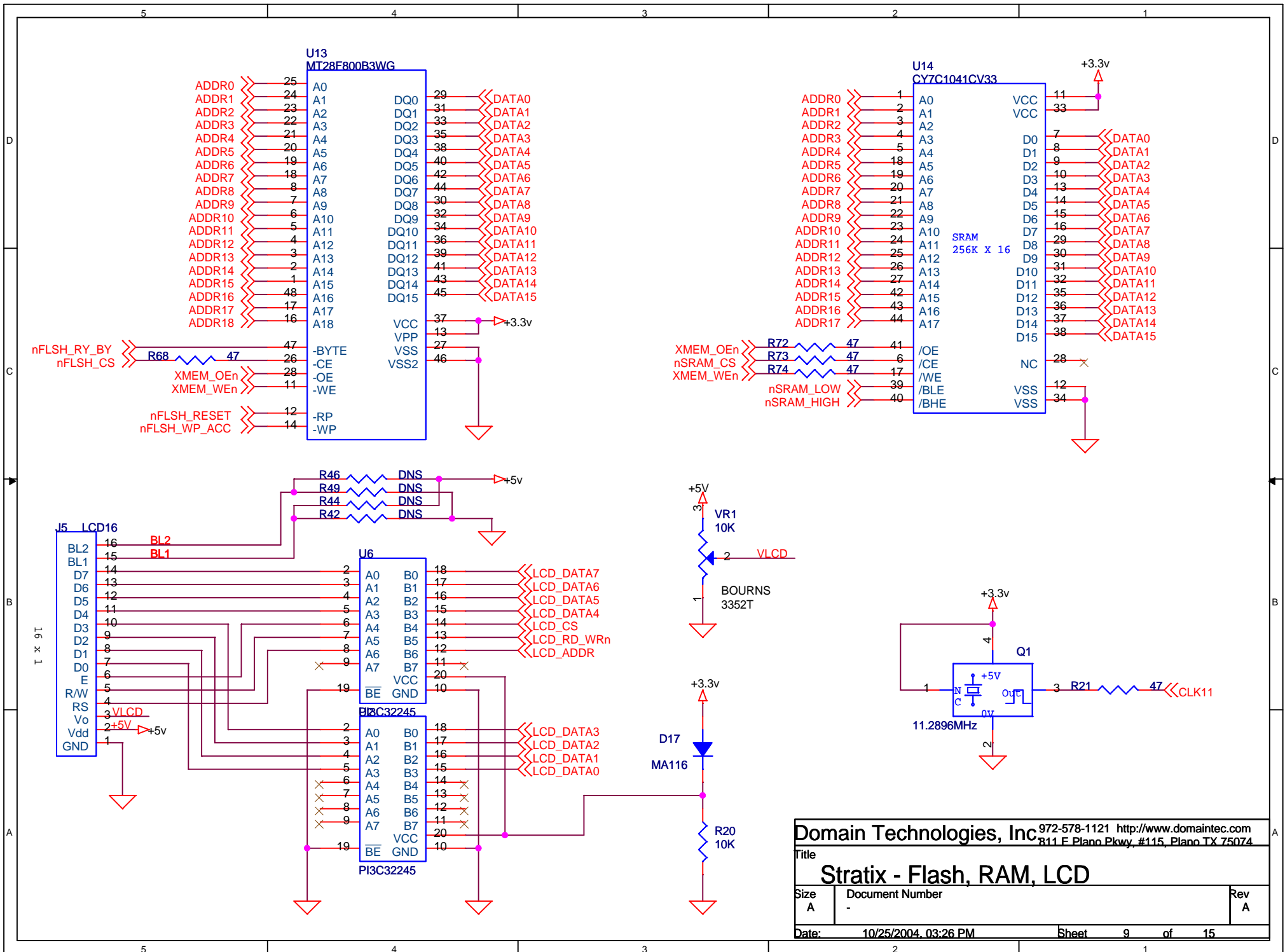

Domain Technologies, Inc 972-578-1121 <http://www.domaintec.com>
 R11 E Plano Pkwy, #115, Plano TX 75074

Title		
Stratix - Flash, RAM, LCD		
Size	Document Number	Rev
A	-	A
Date:	10/25/2004, 03:26 PM	Sheet 9 of 15

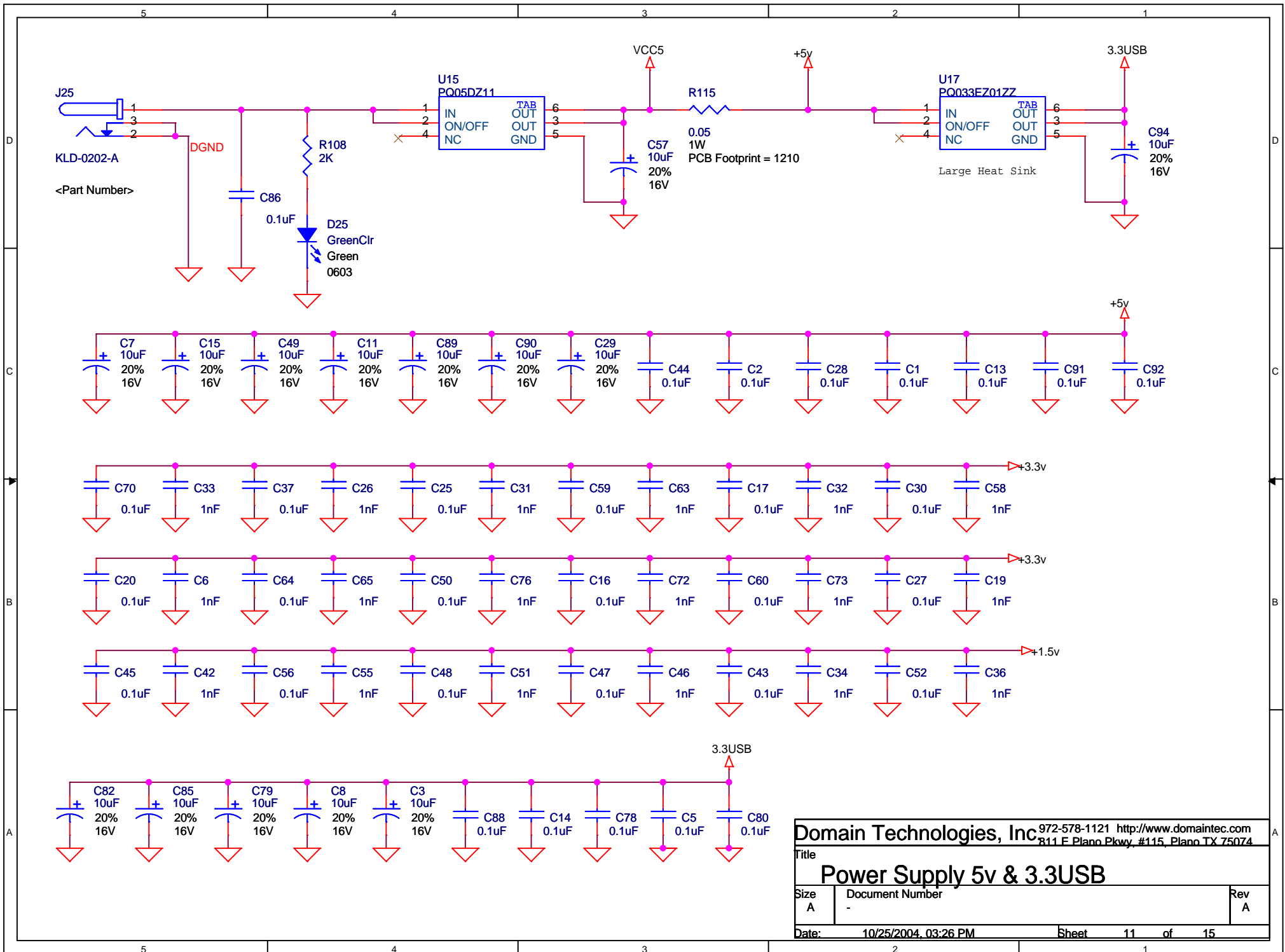

Domain Technologies, Inc 972-578-1121 http://www.domaintec.com 311 E Plano Pkwy, #115, Plano TX 75074		
Title Power Supply 5v & 3.3USB		
Size A	Document Number -	Rev A
Date: 10/25/2004 03:26 PM		Sheet 11 of 15

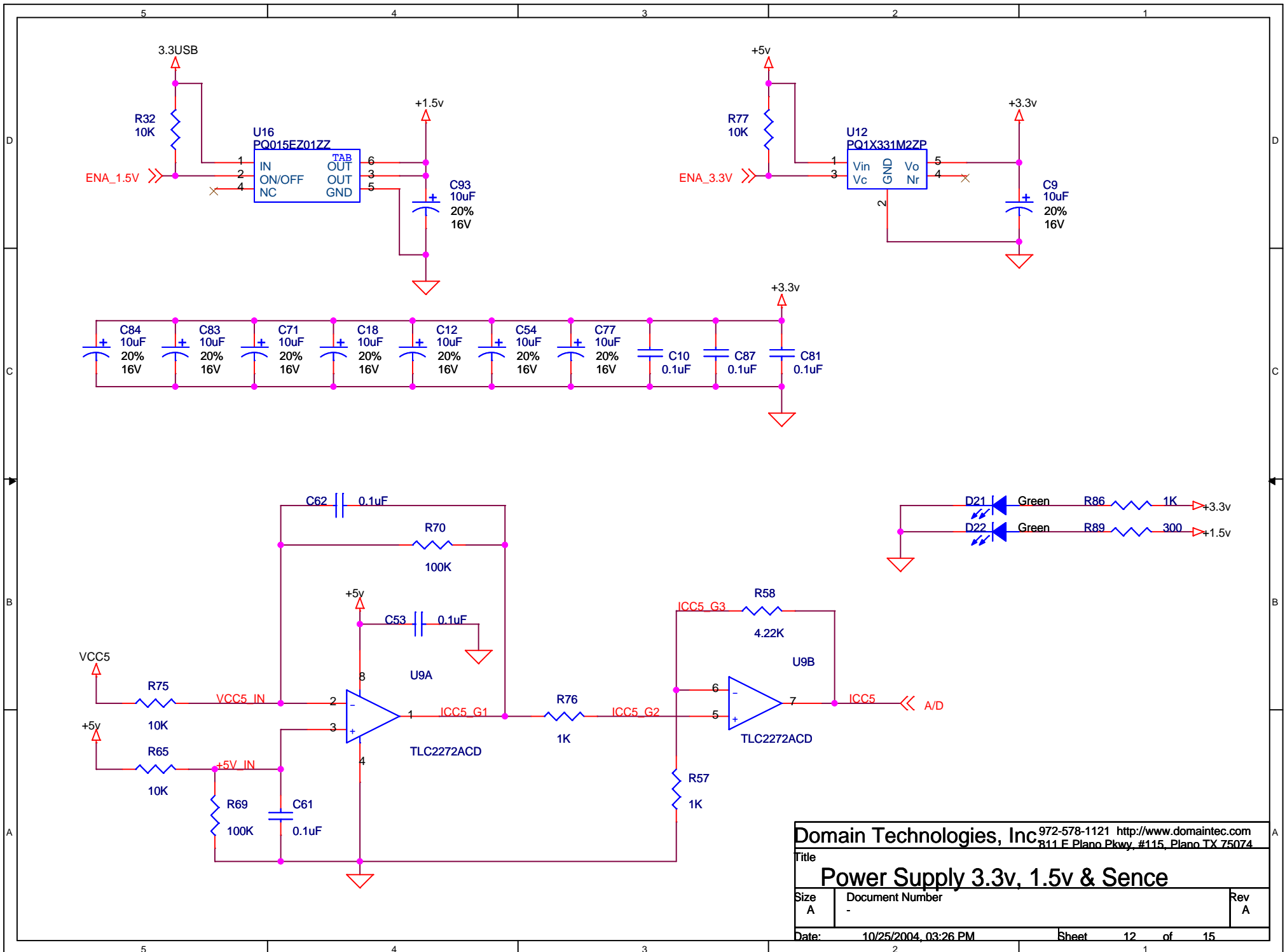

Domain Technologies, Inc. 972-578-1121 <http://www.domaintec.com>
 811 E Plano Pkwy, #115, Plano TX 75074

Title
Power Supply 3.3v, 1.5v & Sence

Size A	Document Number -	Rev A
-----------	----------------------	----------

Date: 10/25/2004, 03:26 PM Sheet 12 of 15

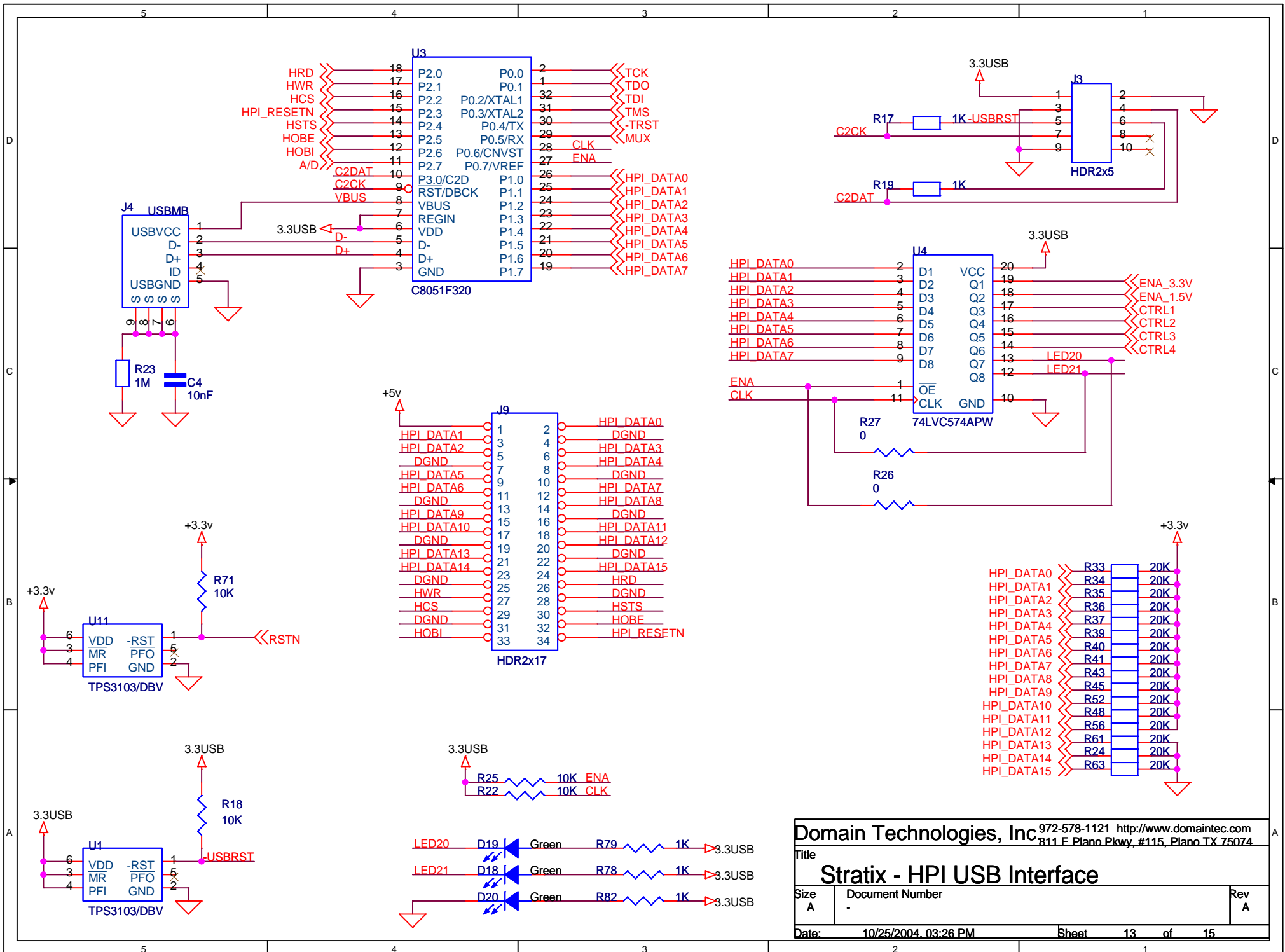

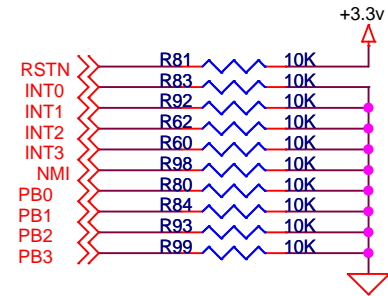
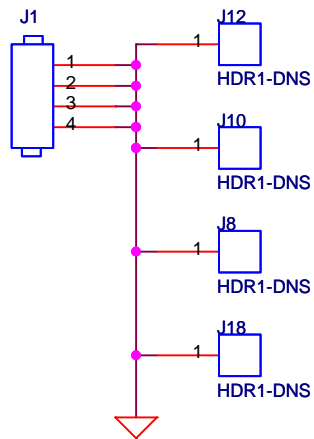
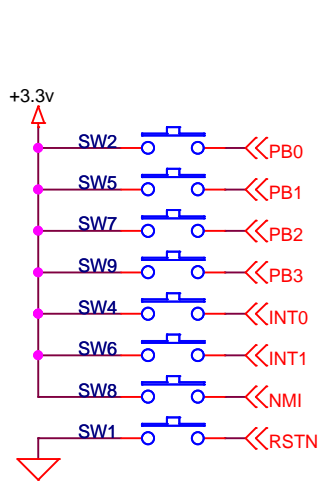
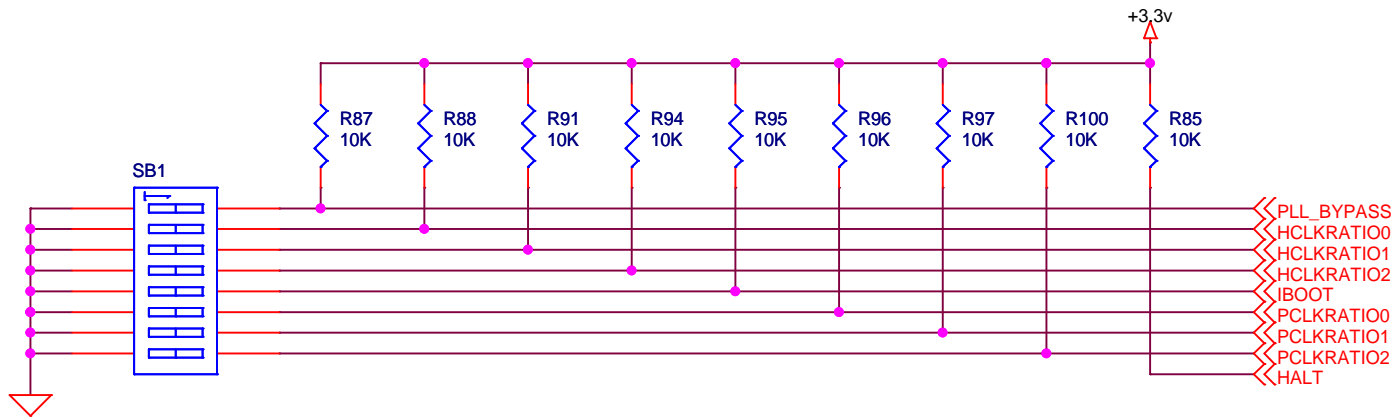

Domain Technologies, Inc 972-578-1121 <http://www.domaintec.com>
 811 E Plano Pkwy, #115, Plano TX 75074

Title		
Stratix - Option switches		
Size	Document Number	Rev
A	-	A
Date:	10/25/2004 03:15 PM	Sheet 14 of 15

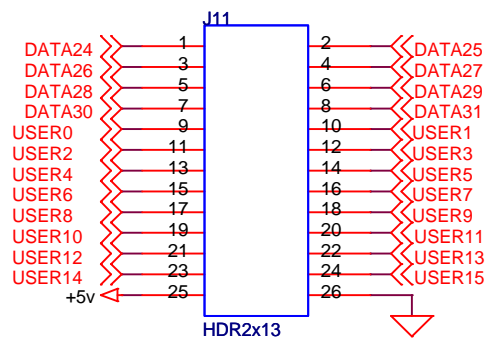
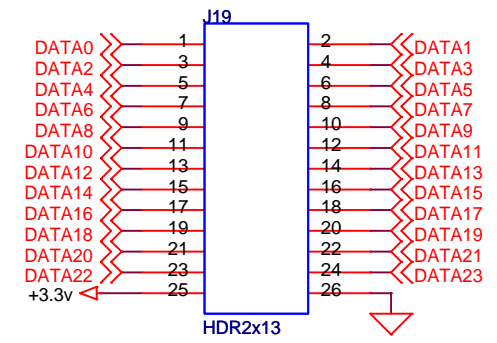
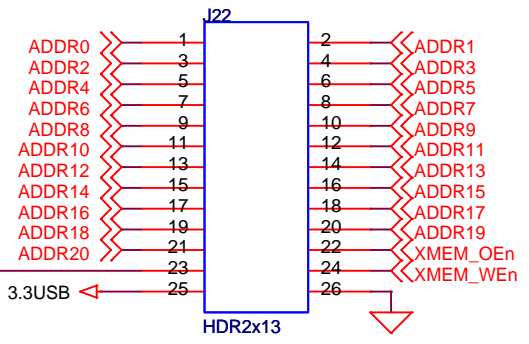
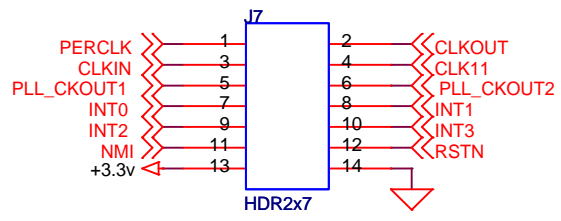
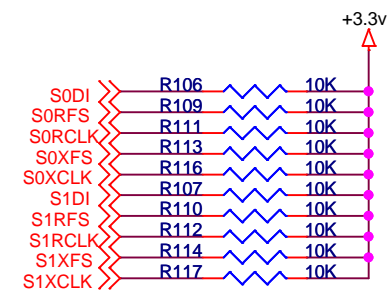
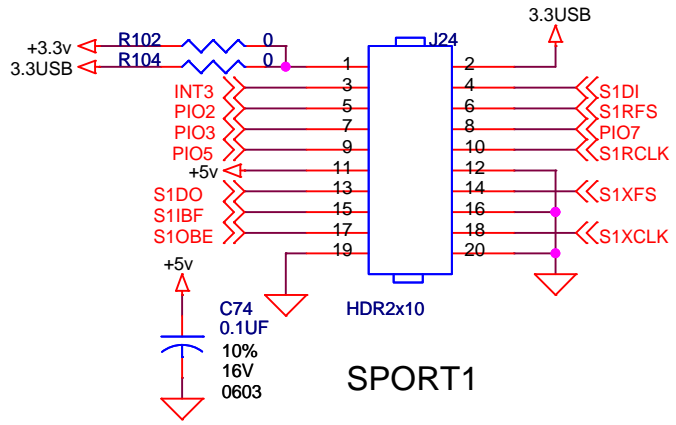
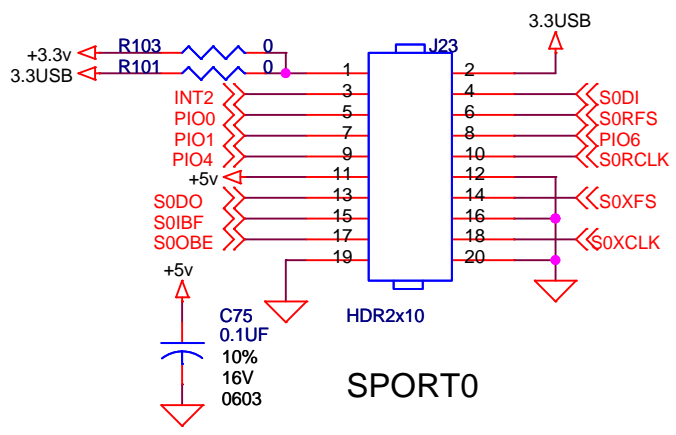

Domain Technologies, Inc 972-578-1121 http://www.domaintec.com		
R11 F Plano Pkwy, #115, Plano TX 75074		
Title		
Stratix - External headers		
Size	Document Number	Rev
A	-	A
Date:	10/22/2004, 10:12 AM	Sheet 15 of 15